

OPERATION AND
MAINTENANCE MANUAL
HPS PLUNGER PUMP

ISSUE 2

25th October 1999

REF. No.: om-manualhps.doc

**Grosvenor Pumps Limited
Trevoole, Praze,
Camborne,
Cornwall.
TR14 0PJ
England**

**Tel: 01209 831500
Fax: 01209 831939
Email: sales@grosvenorpumps.com**

CONTENTS LIST

SECTION TITLE	PAGE
1. GENERAL DESCRIPTION	3
1.1. HPS Plunger Pump	4
2. TECHNICAL DATA	5
2.1. Pump	6
2.2. Motor - Standard	6
2.3. Dimensions	7
2.4. HPS Plunger Pump - Diagram of Parts	8
2.5. Installation Detail - HPS Plunger Pump - RG756 latest issue	9
2.6. Wiring Connection Diagram - Motors - GP 1204 latest issue	10
3. SAFETY	11
3.1. Standard Precautions	12
4. INSTALLATION AND COMMISSIONING	13
4.1. Mounting	14
4.2. Pipe Connections	14
4.3. Gearbox Oil	14
4.4. Electrical	14
4.5. Commissioning	15
4.6. General Operation	15
5. MAINTENANCE	16
5.1. Safety	17
5.2. General Maintenance	17
5.3. Motor	17
5.4. Poppet Suction and Delivery Valve Assemblies	17
5.5. Ball Suction and Delivery Valve Assemblies	18
5.6. Pump Head Assembly	18
5.7. Gearbox Assembly	19
5.8. Final Assembly	19
5.9. Spare parts	20
5.10. Lubrication	20
5.11. Approved Lubricants	20

SECTION 1

GENERAL DESCRIPTION

1. GENERAL DESCRIPTION

1.1. HPS Plunger Pump

- 1.1.1. The HPS Plunger Pump is a fixed output single acting plunger pump. The pump consists of an electric motor driving a worm/worm wheel mesh gearbox with a crank/conrod mechanism. This reciprocates a plunger in a pumphead. Ball or poppet type suction and delivery valves are fitted in the pump head. Typical applications are chemical injection, water treatment dosing, sampling or any other application where a positive liquid feed is required. The pump can be supplied complete within packaged tank units or in a variety of standard or custom built assemblies.
- 1.1.2. The pump duties range from 25 l/h @ 260 bar to 136 l/h @70 bar.
- 1.1.3. The standard 4 pole IP 55 electric motor with a 415 VAC 3 phase 50 Hz supply gives a stroke speed of 100 strokes/minute. Power is dependent upon the duty pressure. Other motor options for hazardous environments or special projects are available on request.
- 1.1.3. The gearbox case is manufactured from cast iron. The standard construction of the pump head and valve assembly is 316L stainless steel with nitrile chevron packings. Other materials are available to special order. The standard units are suitable with liquids upto 130°C.
- 1.1.4. The standard inlet and outlet port connections are available in 1/4" BSP for flow rates upto 68 l/h and 1/2" BSP for higher flows. Other port connections, i.e. NPT, flanges are available on request.
- 1.1.5. A full range of accessories are available including loading valves, relief valves and electrical starters.

SECTION 2

TECHNICAL DATA

2. TECHNICAL DATA

2.1. Pump

Type	Flow@Pressure/Motor Power
5/8" x 1"	25 l/hr @ 85 Bar G/0.37 kW 25 l/hr @ 130 Bar G/0.55 kW 25 l/hr @ 175 Bar G/0.75 kW 25 l/hr @ 260 Bar G/1.1 kW
3/4" 1"	36 l/hr @ 95 Bar G/0.55 kW 36 l/hr @ 130 Bar G/0.75 kW 36 l/hr @ 195 Bar G/1.1 kW 36 l/hr @ 200 Bar G/1.5 kW
7/8" x 1"	54 l/hr @ 85 Bar G/0.75 kW 54 l/hr @ 130 Bar G/1.1 kW 54 l/hr @ 170 Bar G/1.5 kW
1" x 1"	68 l/hr @ 100 Bar G/1.1 kW 68 l/hr @ 140 Bar G/1.5 kW
1-1/8" x 1"	91 l/hr @ 75 Bar G/1.1 kW 91 l/hr @ 100 Bar G/1.5 kW
1-1/4" x 1"	113 l/hr @ 60 Bar G/1.1 kW 113 l/hr @ 60 Bar G/1.5 kW
1-3/8" x 1"	136 l/hr @ 50 Bar G/1.1 kW 136 l/hr @ 70 Bar G/1.5 kW
Material	
Pump head	316L stainless steel
Chevron packing	
Standard	Nitrile
Option	Viton
Valve assembly	316L stainless steel
Suction and Delivery Port	
5/8" x 1" to 1" x 1"	1/4" " BSP
1-1/8" x 1" to 1-3/8" x 1"	1/2" " BSP

2.2. Motor - Standard

Above duties are based on the following motor parameters. Other motor specifications are available on request.

Type	IP 55 4 pole TEFC
Speed	1400 rev/min
Supply	
Standard	415 VAC/3 ph/50 Hz (star) 240 VAC/3 ph/50 Hz (delta)
Optional	240 VAC/1 ph/50 Hz
Operation	Continuous

2.3. Dimensions

Weight	30 kg nett
Overall Length	408 mm
Overall Height	450 mm
Overall Width	208 mm

2.4. HPS Plunger Pump - Diagram of Parts

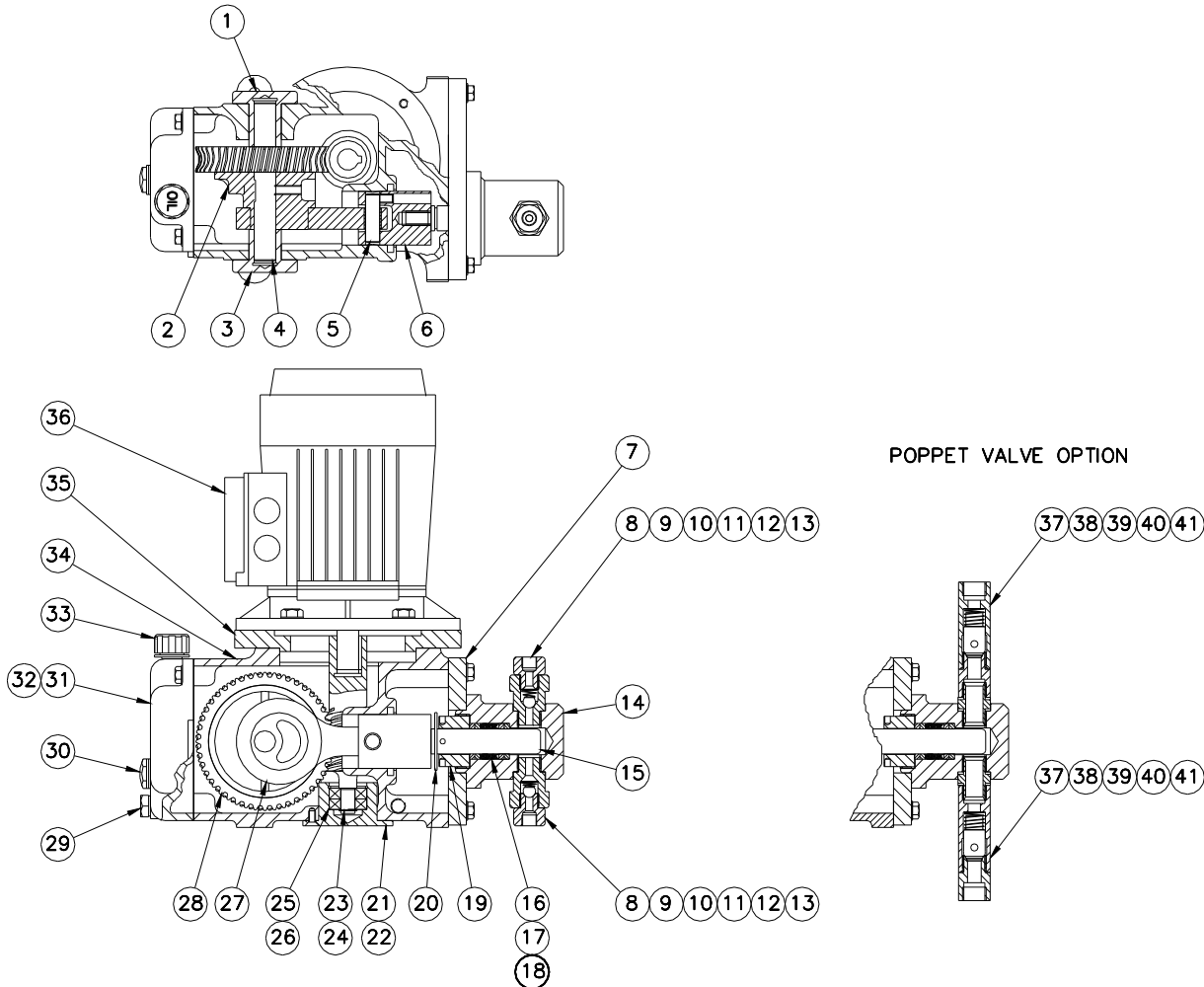

ITEM No.	DESCRIPTION	PART No.	ITEM No.	DESCRIPTION	PART No.
1	MAIN BEARING – LONG	14	21	BEARING HOUSING	207
2	ECCENTRIC	17	22	GASKET – BEARING HOUSING	271
3	MAIN BEARING – SHORT	18	23	WORM	355
4	MAIN SHAFT	19	24	CIRCLIP – SMALL	31
5	CROSS HEAD PIN	22	25	BEARING – WORM	208
6	CROSS HEAD	76	26	CIRCLIP – LARGE	206
7	VALVE TOP – BALL	797	27	CONNECTING ROD	20
8	ADAPTOR – PUMP BODY	932	28	WORM WHEEL	319
9	VALVE BODY – BALL	796	29	OIL DRAIN PLUG	25
10	BALL	115	30	OIL LEVEL PLUG	71
11	SPRING – BALL	795	31	CRANKCASE COVER	185
12	O-RING SEAL – VALVE BODY	815	32	GASKET – CRANKCASE COVER	188
13	WASHER SEAL	72	33	BREATHER	83
14	PUMP BODY	784	34	GEAR BOX	218
15	PLUNGER	1182	35	ADAPTOR PLATE – MOTOR	347
16	NECK RING	734	36	MOTOR	638
17	GLAND PACKING	675	37	VALVE TOP – POPPET	CV22P
18	ANTI-EXTRUSION RING	874/1045	38	VALVE BODY – POPPET	CV23P
19	GLAND NUT	881	39	POPPET	CV27
20	FLINGER	855	40	SPRING – POPPET	CV24
			41	O-RING SEAL – POPPET	1591

2.5. Installation Detail - HPS Plunger Pump RG756 latest issue

<p>DRAWING NUMBER RG756/A3/4</p>	<p>PUMP</p> <table border="1" style="width:100%; border-collapse: collapse;"> <tr> <th>FLOWRATE L/H</th> <th>POWER kW MAX</th> <th>PRESSURE BAR MAX</th> <th>PORT BSP</th> </tr> <tr> <td>25</td> <td>1.1</td> <td>260</td> <td>1/4"</td> </tr> <tr> <td>36</td> <td>1.5</td> <td>200</td> <td>1/4"</td> </tr> <tr> <td>54</td> <td>1.5</td> <td>170</td> <td>1/4"</td> </tr> <tr> <td>68</td> <td>1.5</td> <td>140</td> <td>1/4"</td> </tr> <tr> <td>91</td> <td>1.5</td> <td>100</td> <td>1/2"</td> </tr> <tr> <td>113</td> <td>1.5</td> <td>80</td> <td>1/2"</td> </tr> <tr> <td>136</td> <td>1.5</td> <td>70</td> <td>1/2"</td> </tr> </table>	FLOWRATE L/H	POWER kW MAX	PRESSURE BAR MAX	PORT BSP	25	1.1	260	1/4"	36	1.5	200	1/4"	54	1.5	170	1/4"	68	1.5	140	1/4"	91	1.5	100	1/2"	113	1.5	80	1/2"	136	1.5	70	1/2"	<p>PROJECTION</p>	<p>HP POPPET VALVE OPTION</p>	<p>MOTOR (STD)</p> <p>TYPE D80 FRAME IP 55 4 POLE</p> <p>SPEED 1500 REV/MIN</p> <p>SUPPLY 415 VAC/3 PHASE/50Hz</p> <p>OPERATION CONTINUOUS</p> <p>MATERIAL (STD) 316L STAINLESS STEEL</p> <p>PUMPHEAD NITRILE</p> <p>SEALS</p> <p>TEMPERATURE 1°C MIN. 150° MAX.</p> <p>WEIGHT 33 KG</p> <p>MOTOR CAN BE ROTATED 90° INCREMENTS TO PROVIDE ALTERNATIVE TERMINAL BOX POSITIONS.</p>		<p>DATA SHOWN IS FOR STANDARD ASSEMBLY ONLY. CONTACT GROSVENOR PUMPS FOR FULL DETAILS</p> <p>FILE: PUMP\HPS\INST\RG756</p> <p>DIMENSIONS IN MM</p> <p>ORIGINAL SCALE - 1:5</p>	<table border="1" style="width:100%; border-collapse: collapse;"> <tr> <th>ISSUE</th> <th>DATE</th> <th>ALTERATION</th> <th>CHU</th> <th>SIGN</th> </tr> <tr> <td>4</td> <td>26 NOV 98</td> <td>REDRAWN ON A3 FORMAT</td> <td></td> <td></td> </tr> </table> <p>THIS DRAWING IS CONFIDENTIAL AND IS THE PROPERTY OF GROSVENOR PUMPS LTD. IT MUST NOT BE REPRODUCED EITHER WHOLLY OR PARTLY WITHOUT PERMISSION. COPY RIGHTS ARE RESERVED.</p> <p style="text-align: center; font-size: 2em;">A3</p>	ISSUE	DATE	ALTERATION	CHU	SIGN	4	26 NOV 98	REDRAWN ON A3 FORMAT			<table border="1" style="width:100%; border-collapse: collapse;"> <tr> <th>SHEET</th> <th>TITLE</th> <th>PART NUMBER</th> <th>DRAWING NUMBER</th> </tr> <tr> <td>1 OF 1</td> <td>HPS PLUNGER PUMP INSTALLATION DETAILS</td> <td></td> <td>RG756/A3/4</td> </tr> </table>	SHEET	TITLE	PART NUMBER	DRAWING NUMBER	1 OF 1	HPS PLUNGER PUMP INSTALLATION DETAILS		RG756/A3/4
FLOWRATE L/H	POWER kW MAX	PRESSURE BAR MAX	PORT BSP																																																							
25	1.1	260	1/4"																																																							
36	1.5	200	1/4"																																																							
54	1.5	170	1/4"																																																							
68	1.5	140	1/4"																																																							
91	1.5	100	1/2"																																																							
113	1.5	80	1/2"																																																							
136	1.5	70	1/2"																																																							
ISSUE	DATE	ALTERATION	CHU	SIGN																																																						
4	26 NOV 98	REDRAWN ON A3 FORMAT																																																								
SHEET	TITLE	PART NUMBER	DRAWING NUMBER																																																							
1 OF 1	HPS PLUNGER PUMP INSTALLATION DETAILS		RG756/A3/4																																																							

2.6. Wiring Diagram GP1204 latest issue

DRAWING NUMBER GP1204/A3/1	PROJECTION 	<p>CONNECTION DIAGRAM FOR 3 PHASE SINGLE SPEED INDUCTION MOTOR</p> <p>6 LEADS FOR STAR (Y) OR DELTA (Δ)</p> <p>H HEATER</p> <p>CONNECT TO SINGLE PHASE VOLTAGE SUPPLY</p>	SHEET 1 OF 1	TITLE WIRING CONNECTIONS ALL PUMPS & MIXER MOTORS	PART NUMBER DRAWING NUMBER GP1204/A3/1
			<p>FILE:\COMPNNTS\MOTOR\GP1204</p> <p>DIMENSIONS IN MM</p> <p>ORIGINAL SCALE N/A</p>		
		A3	REMOVE ALL BURRS AND SHARP EDGES. DO NOT SCALE IF IN DOUBT ASK.		
		CHU JTL SIGN	REDRAWN ORIGINAL ISSUE ALTERATION		
		1 14 MAY 98 0 4 FEB 93	THIS DRAWING IS CONFIDENTIAL AND IS THE PROPERTY OF GROSVENOR PUMPS LTD. AND MUST NOT BE REPRODUCED EITHER WHOLLY OR PARTLY WITHOUT THE WRITTEN CONSENT. RIGHTS ARE RESERVED.		

SECTION 3**SAFETY**

3. SAFETY

3.1. Standard Precautions

- 3.1.1. To comply with normal safety standards, the following measures are to be taken:
- 3.1.2. A minimum issue of standard protective clothing to be available to all personnel involved in the handling of chemicals and operation of the dosing plant, consisting of:
- 3.1.3. Goggles - with wide-angle vision, contact the skin in complete seal around both eyes and adequately vented without allowing access to spillage.
- 3.1.4. Safety helmet - of metal or reinforced plastic to the relevant British Standard or equivalent.
- 3.1.5. Gloves - wrist length, of soft PVC or rubber permitting full flexure.
- 3.1.6. Overalls - to be worn in conjunction with the items above or a one-piece chemical suit.
- 3.1.7. Standard site safety provisions, safety precautions and first aid instructions, in condensed form shall be declared at site and in site vehicles. All employees shall be in possession of literature giving full details of safety precautions and first aid action.
- 3.1.8. Ensure that the nature and properties of the chemical being handled are known in advance.
- 3.1.9. Ensure that the correct precautions for the chemical being handled are observed. IF IN DOUBT ASK.
- 3.1.10. Treat all materials as harmful.
- 3.1.11. Do not touch chemicals or residues with bare hands.
- 3.1.12. Maintain personal cleanliness.
- 3.1.13. Wash contaminated clothing before re-use.
- 3.1.14. Wash thoroughly after handling chemicals. Do not eat drink or smoke unless decontaminated.
- 3.1.15. Erect WARNING barriers where necessary.
- 3.1.16. Follow specific process instruction carefully.
- 3.1.17. Mix chemicals in the order specified.
- 3.1.18. **CAUTION: CHEMICALS CAN BE HARMFUL. PLEASE OBSERVE MANUFACTURER'S HANDLING AND STORAGE GUIDELINES.**
- 3.1.19. Health Hazards - Harmful in contact with the skin and irritating to the eyes.
- 3.1.20. Handling - Avoid contact with the skin and eyes. Wear suitable protective clothing gloves and eye protection. Wash out empty container thoroughly with water and add solution to system being treated.
- 3.1.21. Storage - Keep container in a cool, well ventilated place. Keep away from source of ignition. NO SMOKING.
- 3.1.22. Spillage and Disposal - Shut off all sources of ignition. Absorb spillage in earth and sand, collect up and remove all contaminated clothing. Eye exposure; in case of contact with eyes, rinse immediately with copious quantities of water. Ingestion; remove patient to fresh air, rest and warm. Administer oxygen or artificial respiration as necessary.

SECTION 4

INSTALLATION, COMMISSIONING & OPERATION

4. INSTALLATION, COMMISSIONING & COMMISSIONING

4.1. Mounting

- 4.1.1. For maximum operating life, the pump should be located in a clean cool dry environment. If the site is classified as a hazardous area ensure the pump meets the site requirements. Position the pump on a rigid base preferably as low as possible relative to the supply for the optimum suction condition. Fix the pump gearbox firmly to the base using four suitable floor bolts.
- 4.1.2. If the pump is to be installed in an aggressive, hot, dirty environment, it is advisable to provide some cover. However it is essential to leave adequate ventilation for motor cooling. Do not obstruct the motor fan cover.

4.2. Pipe Connections

- 4.2.1. The suction pipe sizes should be larger than the port connection. The number of pipe bends should be kept to a minimum to reduce flow losses, pulsation and water hammer effects. Increase the pipe size if long pipe runs are unavoidable. If water hammer is present, fit a pulsation damper unit in the delivery pipe line as close to the pump as possible. For technical advice, please refer to Grosvenor Pumps.
- 4.2.2. The pump is designed to be self-priming. However, if difficulties are experienced with priming, loosen/remove the delivery valve sub-assembly, fill the pumping chamber with the pumped liquid and refit the valve. Appropriate care should be taken if the liquid is harmful.
- 4.2.3. Allow sufficient time to fill large diameter and/or long pipe lengths to build up hydraulic pressure. If the pressure does not increase, check:-
 - All joints are tight and fully sealed and any dump/flushing valves are shut.
 - The relief valve is adjusted to the correct pressure.
 - The suction and delivery lines are connected to the correct pump ports.
 - The liquid is free of large debris and contaminants. Large solids will reduce valve efficiency. Fit a suction strainer/filter.
 - Entrapped air pockets. Bleed the system.
- 4.2.4. If there is a high suction head present, a loading valve may be required to prevent syphoning.

4.3. Gearbox Oil

- 4.3.1. Note the pump gearbox is supplied without lubrication oil. Unscrew the breather unit and fill the gearbox with a sufficient quantity of suitable oil (refer to Section 6 - Maintenance for approved lubricants). The level should be no higher than the oil level plug.

4.4. Electrical

- 4.4.1. Before beginning any electrical work, isolate the supply at the mains.
- 4.4.2. Open the motor terminal box. Connect a suitably rated power supply to the motor. Use suitable power multi-core power cable with a cable gland nut. Fasten the power leads firmly to the terminal points. Always connect the supply earth lead.

- 4.4.3. Three phase motors can be controlled by a direct on-line starter or a frequency inverter. The standard motors can be wired in star or delta with a corresponding voltage variation e.g. either 415 VAC or 240 VAC. Therefore check the power supply.
- 4.4.4. The motor rotation should be anti-clockwise when viewed from the fan side. For three phase supply, if the rotation is clockwise, change any two of the three supply phases over. The direction for single phase motors has been factory set to be anti-clockwise. However, if the rotation is clockwise interchange the blue and yellow leads on terminals 2 and 3.
- 4.4.5. As the pump will operate upto the motor stalling point, it is recommended that an electrical overload trip device is fitted and/or a hydraulic relief valve fitted in the delivery line. To allow for start-up current surge, current trips should be 6 to 7 times the full load motor current. If the supply is from a frequency inverter, the motor should be specified with a thermistor which is compatible with the frequency inverter. Unless a blower is fitted to the motor, turndown must be limited to 3:1 with an inverter.

4.5. Commissioning

- 4.5.1. After pipe and electrical installation has been completed run the pump between 30 and 60 minutes at minimum hydraulic pressure and full flow. Examine the entire hydraulic system including the pump for any leakages. Check the pump for unusual noises and vibration. For the first 14 days operation, expect the pump gearbox to run at a temperature of 65-70°C. This will in no way affect the overall pump performance.

4.6. General Operation

- 4.6.1. Operate the pump within the duty specified in the customer's order. Please note that the performance data specified in section 2.1. is the maximum capable for each pump.
- 4.6.2. Never run the pump dry for more than 5 minutes or the plunger chevron packing will wear out prematurely.
- 4.6.3. Check the pump will operate satisfactorily if it is to be used for another duty, i.e. different liquid, pressure, environment, power supply.
- 4.6.4. Always handle the pump by gripping the gearbox case and not by the pump head or any pipework attached to the pump head.
- 4.6.5. For long plunger packing life it is acceptable for slight leakage at the gland. The packing relies on the liquid it is sealing for lubrication. Never overtighten the gland nut or the packing will run dry and wear out prematurely. Should gland leakage be greater than 1 drop per second, tighten the gland nut by 15°. Run the pump and observe any leakage. Repeat as required until leakage is at an acceptable level. If the packings still leaks after a full turn, they will need replacing.
- 4.6.6. Check the pump for excessive vibration and overheating.
- 4.6.7. Ensure that all associated instruments are functioning correctly and the readings are meaningful. Periodically check the pump is maintaining delivery and pressure. Check the motor current is within its acceptable operation limit.

SECTION 5

MAINTENANCE

5. MAINTENANCE

5.1. Safety

- 5.1.1. **CAUTION: BEFORE STARTING ANY MAINTENANCE PROCEDURE, ENSURE THAT ALL SAFETY INSTRUCTIONS DETAILED IN THE CURRENT WORKS MANUAL AND STANDARD PROCEDURES HAVE BEEN COMPLIED WITH.**

5.2. General Maintenance

- 5.2.1. General maintenance is an oil change every 6 months. If the pump is in continuous operation at maximum duty, a detailed inspection of parts will be required at 12 month intervals. The pump unit is easily dismantled using standard engineers' tools. No special tools are required.

5.3. Motor

- 5.3.1. Isolate electric supply, disconnect wires from terminal box. After removing the flange bolts, the motor lifts off the mounting flange. The motor shaft is located in the worm with a close tolerance fit. The motor may require some considerable force to separate it from the gearbox. The motor is non-serviceable.
- 5.3.1. To refit the motor, insert the shaft into the worm, ensuring key (1083) is not displaced. Press the motor fully down onto the mounting flange. Retighten the motor flange bolts.
- 5.3.2. Reconnect the wiring to ensure rotation is anti-clockwise when viewing motor on the fan end.

5.4. Poppet Suction and Delivery Valves Assemblies

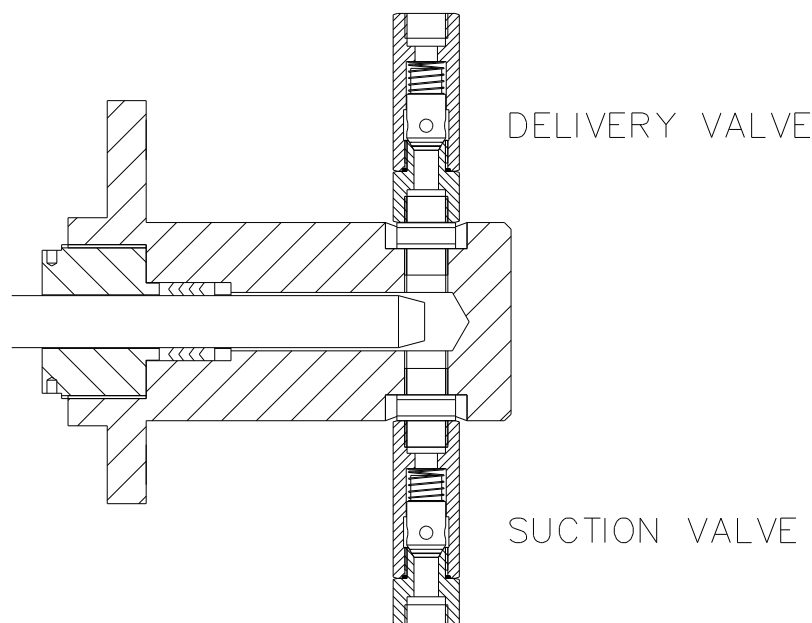

- 5.4.1. Note the orientation of the parts which make up the suction and delivery valve assemblies. Unscrew the valve assembly from the pump head. Separate the valve body (CV23P) from the valve end (CV22P). Extract the poppet (CV27) and spring (CV24). Examine the poppet, O-Ring (1591) and the valve top sealing seat for wear damage. Replace as required. Always renew the valve body O-rings and valve poppet O-rings.
- 5.4.2. Check the poppets and valve ends are replaced in the respective valve bodies in their correct suction or delivery orientation. Tighten the valve assemblies to 15 Nm.

5.5. Ball Suction and Delivery Valves Assemblies

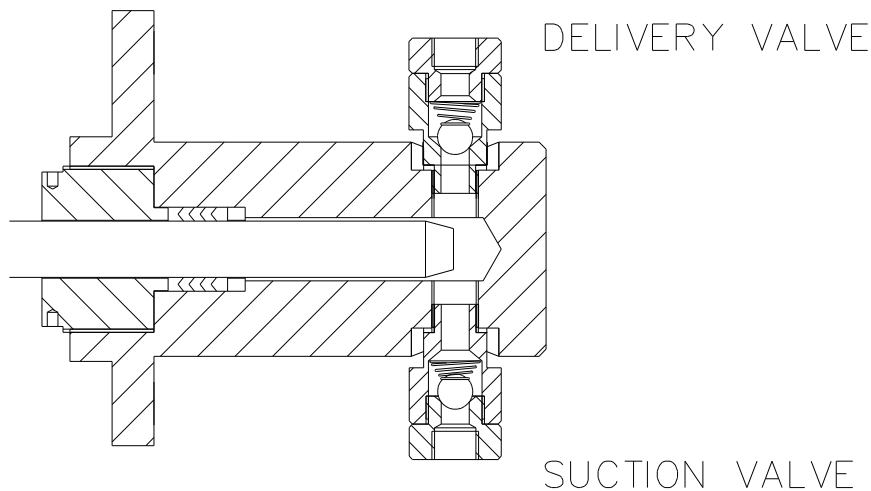

- 5.5.1. Note the orientation of the parts which make up the suction and delivery valve assemblies. Unscrew the valve assembly from the pump head. Separate the valve body (796) from the valve top (797). Extract the ball (115) and spring (795). Examine the ball and valve sealing seat condition for wear damage. Always renew the valve body O-rings.
- 5.5.2. Check the balls and springs are replaced in the respective valve bodies in their correct suction or delivery orientation. Tighten the valve assemblies to 15 Nm.

5.6. Pump Head Assembly

- 5.6.1. The pump head assembly must be removed from the gearbox to replace the chevron packing set (675) or the plunger (1182). Rotate the motor by hand to move the plunger and cross head (76) to the back stroke position.
- 5.6.2. Slacken off the gland nut (881). Remove the four bolts holding the pump body (784) to the gearbox. All parts are now accessible for replacement if necessary.
- 5.6.3. Unscrew the plunger from the crosshead. Examine for surface wear. Light marking can be polished out with a fine metal polish. Deep scoring or corrosion damage will require a replacement plunger. Refit the plunger with a thread sealant e.g. Loctite 270 or an equivalent.

- 5.6.4. Unscrew the gland nut. Extract the back PETP and PTFE anti-extrusion rings (874 and 1045) followed by the chevron packing set and the neck rings (734). Examine for wear damage and replace as required.
- 5.6.5. Reassemble in the reverse order ensuring the correct orientation of the neck ring, chevron packing set and the PETP and PTFE anti-extrusion rings. Screw the gland nut loosely back onto the pumphead. Wet the plunger and gently ease the pump head over the plunger. Secure the pump head to the gearbox with the four bolts. Torque to 20 Nm.
- 5.6.6. Reconnect the suction and delivery pipework.
- 5.6.7. Check the chevron packing sealing integrity. Hand tighten the gland nut. Then give turn it a 15°. Start the pump with minimum hydraulic load. For long gland packing life it is acceptable to have gland leakage. As a guide, 1 drop per second is a maximum. The gland packing relies on the leakage as its only form of lubrication. Should any gland leakage be greater than 1 drop per second, tighten the gland nut by 15°. Run the pump and observe any leakage. Repeat as required until the leakage is at an acceptable level. If the gland still leaks badly after a full turn, the packing will need replacing. Never overtighten the gland nut. Otherwise the packing will run dry and wear out.

5.7. Gearbox Assembly

- 5.7.1. It is impractical to service the gearbox assembly with the pump is still mounted on the skid base frame. Work is carried out after removing the complete motor as in 5.3. and pumphead assembly 5.6..
- 5.7.2. Drain the gearbox oil by removing the drain plug (25). Remove the crankcase cover (337). If fitted, remove the motor plate (347). On the bottom face of the pump gearbox, unscrew the three countersunk head screws holding the bottom bearing housing (270). With a pair of internal circlip pliers remove the retaining circlip holding the two worm bearings (208) in the bottom bearing housing. After separating the bottom bearing housing, remove the circlip holding the two worm bearings to the worm (355). Remove the lock grub screw in the eccentric (17). Remove the long and short main bearings (14/18) and push the main shaft (19) out. Pull out the connecting rod (20) and crosshead (76). Remove the crosshead pin lock screw and push out the crosshead pin (22).
- 5.7.3. Examine all parts for severe wear or damage. Replace any parts as required.
- 5.7.4. Reassembly of gearbox is reverse of 5.6.2.. Replace all gaskets and seals.

5.8. Final Assembly

- 5.8.1. Fit the Motor.
- 5.8.2. Fit Nameplate and Crosshead Guard
- 5.8.3. Connect wiring to give correct rotation.
- 5.8.4. Run-in for the Gearbox for 2 hours. Drain the gearbox and refill with fresh oil.
- 5.8.5. Replace pumphead and valve assemblies. The complete pump is ready for commissioning. Check the pump for unusual noises and vibration. For the first 14 days operation, expect the pump gearbox to run at a temperature of 65-70°C. This will in no way affect the overall pump performance.

5.9. Spare Parts (Ref: Section 2.4 HPS Plunger Pump - Diagram of Parts)

- 5.9.1. Spare parts can be identified to drawing by part number. Always quote pump serial number which can be found on pump crankcase cover. Parts should be ordered from:-

**Grosvenor Pumps Limited,
 Trevoole, Praze,
 Camborne Cornwall. TR14 0PJ
 Tel. 01209 831500 Fax. 01209 831939**

5.10. Lubrication

- 5.10.1. The pump is empty when supplied, but should be filled before commissioning. Recommended grades are shown on pump nameplate for major oil companies. Equivalent grades for other oil companies are listed here. The oil level is determined by level plug and should be checked weekly. Change approximately every 6 months. All gearbox parts are lubricated by splash. Motor bearings are fully charged with grease for life by manufacturer.

Oil capacity - 0.7 litres Approx.

5.11. Approved Lubricants

- 5.11.1. Oil grades based on ambient temperatures, suitable for normal applications. The recommendations are based on current information available and responsibility cannot be accepted for quality or suitability of oil supplied nor to any mechanical defect due to unsatisfactory lubrication.
- 5.11.2. Oils marked * contain mild E.P. additives and should not be used for units operating above 80^oC normal running temperatures.
- 5.11.3. In general these oils should not be used below -4^oC. If intended for such use, Grosvenor Pumps can recommend suitable oils for lower temperatures. Oils marked # are usually obtainable at most garages and motor factors.

SUPPLIER

BP Oil Ltd.

Burmah - Castrol (UK) Ltd.

Esso Petroleum Ltd.

Mobil Oil Co. Ltd.

Shell

Texaco Ltd.

OILS

Energol HLP 320

Energol CS 320 *

Hypogear 90 EP #

Alpha ZN 320

Castrol ST 90 #

Hypoy EP 90 #

Teresso 320

GX 85W/90

DTE AA

HD 140 #

GX 140 #

Vitrea 320 *

Tellus V320

HD 90/140#

Regal R & O 320